



STANDARDS COMPLIANCE:

- ASSE® Listed 1013
- CSA® Listed
- AWWA Compliant C511
- City of Los Angeles Approved
- Approved by the Foundation for Cross-Connection Control and Hydraulic Research at the University of Southern California (horizontal 3/4", 1", 1 1/2", 2")
- NYC Dept of Building MEA 324-93-M Vol. 1



FEATURES:

Sizes: □ 3/4" □ 1" □ 1 1/4" □ 1 1/2" □ 2"

Max. working water pressure 175 PSI (1200 kPa)
 Max. working water temperature 180°F (82°C)
 Hydrostatic Test Pressure 350 PSI (2400 kPa)

MATERIALS:

Valve Body Unleaded Bronze (Federalloy I-836)
 Access Cover Unleaded Bronze (Federalloy I-836)
 Polymers Noryl™, NSF Listed
 Elastomers Silicone
 Springs Stainless Steel

OPTIONS:

- 1 – less ball valves (ex B9210E replace 3rd number)
- UE– with union end ball valves
- S – with bronze “Y” type strainer

FLOMATIC SPECIFICATIONS:

Reduced Pressure Principle backflow preventer shall protect against backflow by either backpressure or backsiphonage from a cross-connection between potable water systems and substances that are non-health and health hazards.

The device shall be constructed from unleaded bronze with less than 0.05% lead content (Federalloy I-836 or approved equal). It shall consist of two (2) mechanically independent, spring loaded, center stem guided check valves. It shall also have a hydraulically dependent differential pressure relief valve with the sensing passage set in an integral cast unleaded bronze body, with a single access cover. The assembly shall have four (4) vertical test cocks and two shut off valves which are quarter-turn, full-port, resilient seated and ball type which are constructed with low lead material, less than 0.25% lead content (ASTM C90500) or approved equal.

The relief valve shall have removable stainless steel seat ring. The check valves shall be held into place by stainless steel clips and the check valve assemblies shall be non-interchangeable with silicone discs.

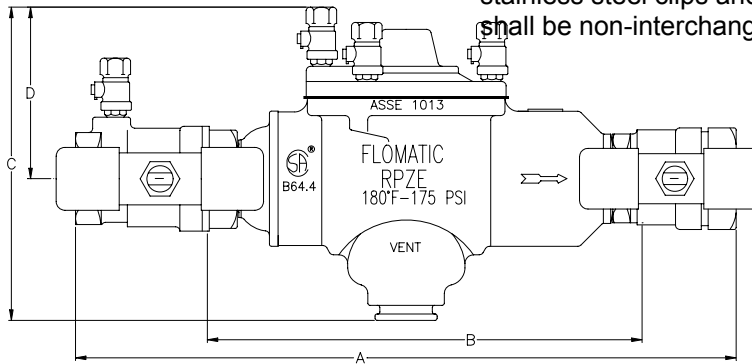

Size		Part #	A		B		C		D		Width		Wgt with BV		Wgt less BV	
Inch	mm		Inch	mm	Inch	mm	Inch	mm	Inch	mm	Inch	mm	lbs	kg	lbs	kg
3/4	20	B9200E	12	305	8	203	6-1/8	156	3-3/4	96	4	102	8.5	4	7	3.25
1	25	B9201E	13	330	8	203	6-1/8	156	3-3/4	96	4	102	9.5	4.5	7	3.25
1-1/4	32	B9202E	14-3/8	365	9	229	7-1/4	184	4-1/8	105	4-9/16	116	13	6	8.5	4
1-1/2	40	B9203E	19	483	12-1/2	318	9	229	5	127	5-3/4	146	27.5	12.5	21	9.5
2	50	B9204E	20	508	12-1/2	318	9	229	5	127	5-3/4	146	32	14.5	21	9.5

FLOW CHARACTERISTICS

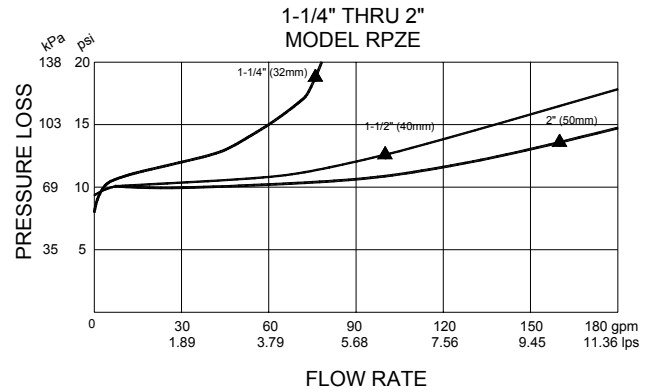
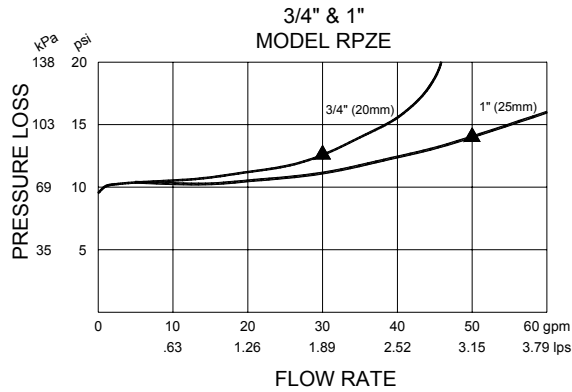

▲ RATED FLOW
(Established by Approval Agencies)

TYPICAL INSTALLATION

Model RPZE Reduced Pressure Backflow Preventers should be installed with adequate clearance and easy accessibility for testing and maintenance and must be protected from freezing. Local codes shall govern installation requirements. Unless otherwise specified, the assembly shall be mounted at a minimum clearance of 12" (305mm) between port and floor or grade. The assembly shall have a maximum of 30" (762mm) above adequate drains with sufficient side clearance for testing and maintenance. The installation shall be made so that no part of the unit can be submerged. Thermal water expansion can cause excessive pressure. Excessive pressure situations should be eliminated to avoid possible damage to the system and assembly.

Capacity thru Schedule 40 Pipe (GPM)				
Pipe size	5 ft/sec	7.5 ft/sec	10 ft/sec	15 ft/sec
3/4"	8	12	17	25
1"	13	20	27	40
1 1/4"	23	35	47	70
1 1/2"	32	48	63	95
2"	52	78	98	157

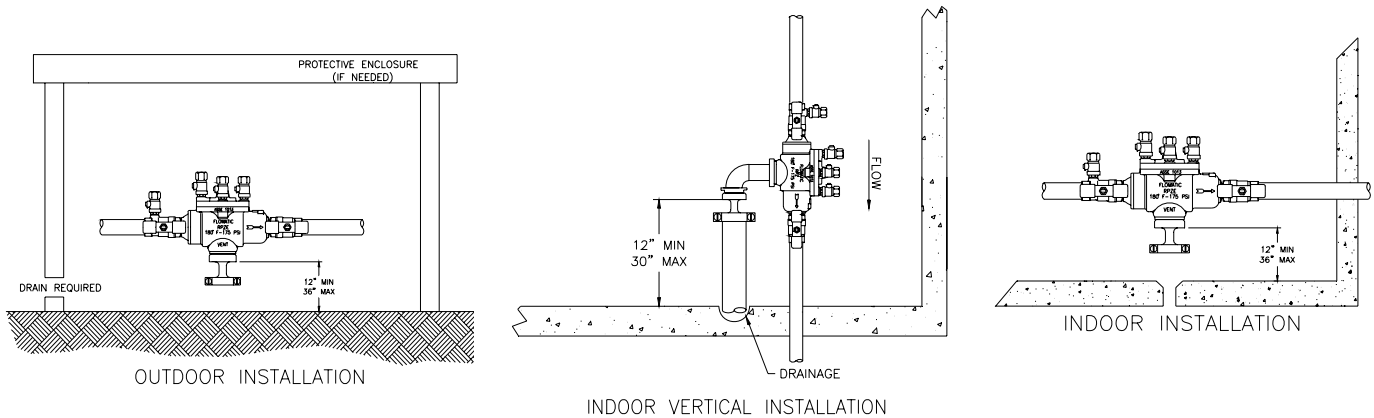

WARRANTY: Danfoss Flomatic valves are guaranteed against defects of materials or workmanship when used for the services recommended. If in any recommended service, a defect develops due to material or workmanship, and the device is returned, freight prepaid, to Danfoss Flomatic within 12 months from the date of purchase, it will be repaired or replaced free of charge. Danfoss Flomatics' liability shall be limited to our agreement to repair or replace the valve only.